

A

B

NOTES: (UNLESS OTHERWISE SPECIFIED)

1. ASSEMBLY WEIGHT: .05 LBS MAX
2. PROTECT COSMETIC SURFACES FROM DAMAGE

REVISIONS						
ZONE	REV	DESCRIPTION	DATE	BY	EC NO.	APRV
	A	INITIAL RELEASE	02/06/18	MCS	18-0080	
NOTES	B	REMOVE QCP NOTE, CHANGE PROJECT FROM "SMARTFLEX" TO "MIP"	06/05/18	SC	18-0373	BEF

Electronic Revision Controlled

BRUSHED BLACK ANODIZED SURFACE THIS SIDE

STEEL PLUGS USED FOR MAGNETIC RETENTION

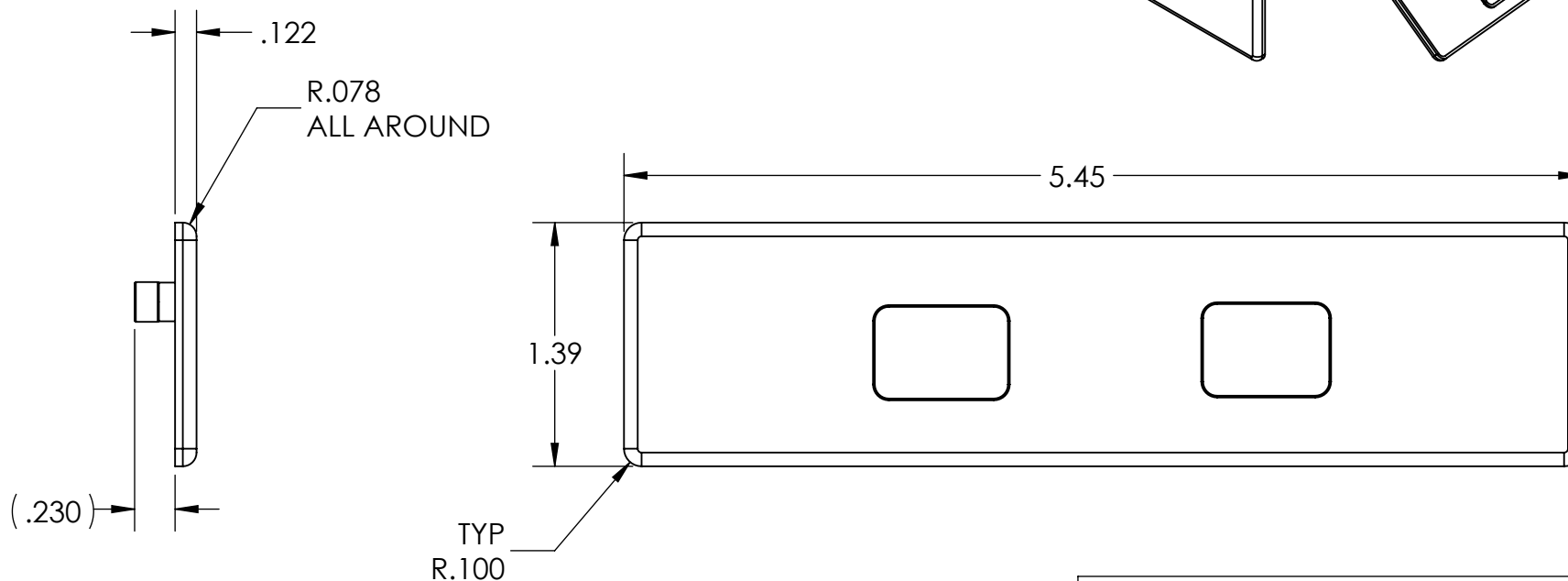

THE INFORMATION CONTAINED HEREIN IS PROPRIETARY TO ROSEN AVIATION, LLC. IT SHALL NOT BE REPRODUCED OR DISCLOSED IN WHOLE OR IN PART OR USED FOR ANY DESIGN OR MANUFACTURE EXCEPT WHEN SUCH USER POSSESSES DIRECT, WRITTEN AUTHORIZATION FROM ROSEN AVIATION, LLC. THIS DRAWING MAY BE COVERED UNDER ONE OR MORE U.S. OR INTERNATIONAL PATENTS. PLEASE CONTACT ROSEN AVIATION FOR SPECIFIC INFORMATION.

ROSEN AVIATION
 1020 OWEN LOOP SOUTH
 EUGENE, OREGON 97402
 TEL: (541) 342-3802 FAX: (541) 342-4912

APPROVALS	INITIAL	DATE
DRAWN BY	MCS	01/31/18
CHECKER	BEF	02/02/18
ENGINEER	MCS	02/02/18

TITLE
**OUTLINE AND INSTALLATION
 DRAWING, MIP, BEZEL, ANODIZED**

MIP100-901-CD

UNLESS OTHERWISE SPECIFIED DIMENSIONS ARE IN INCHES
 .X = ±.1
 .XX = ±.02
 .XXX = ±.005
 ∠ = ± 1.0°
 RADII ± .020
 INTERPRET DIM AND TOL PER ASME Y14.5M - 1994

FIRST CALLED FOR: (PCF)
359-MIP

SIZE	REV
A	B
SCALE: 1:1 SHEET 1 OF 1	

A

B © 2018 ROSEN AVIATION, LLC