

NOTES: (unless otherwise specified)

1. ASSEMBLY WEIGHT = 3.5 LBS MAX
2. REFER TO ROSEN MODEL #0603-003 FOR DETAIL
3. FREE AIR VENTILATION REQUIRED. LEAVE PERFORATED VENT AREAS ON THE FRONT AND BACK SURFACES UNBLOCKED FOR VENTILATION. ONE INCH (1") MINIMUM CLEARANCE TO ANY BAFFLES OR BENDS IN DUCTING. A VENT PATTERN OR OPENING IN CABINET MUST HAVE 5.5 SQUARE INCHES OF OPEN AREA
4. USE RGB OUTPUT TO MONITORS LARGER THAN 10.4" FOR BEST VIDEO CLARITY
5. SEE SHEET 2 FOR 0603-003 MOD 02 DETAILS. NO CHANGES OF FORM, FIT, FUNCTION, OR MOUNTING

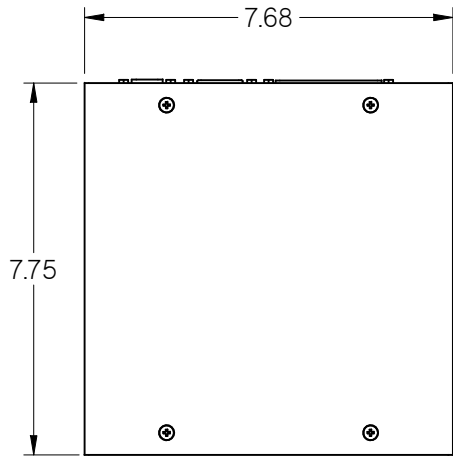

VIEWS THIS SHEET DEPICT
MOD 00 AND MOD 01

**ELECTRONIC REVISION
CONTROLLED**

REVISIONS						
ZONE	REV	DESCRIPTION	DATE	BY	CHG NO	APRV
	1.0	INITIAL DRAWING RELEASE	07/08/13	GJH	NEC13-103	DE
	A	RELEASE FOR PRODUCTION	11/11/13	GJH	13-0401	
pg2	B	ADDED P/N 0300-412 TO CONTROLLERS	12/19/13	GJH	13-0449	DE
pg2	C	REMOVE S-VIDEO FROM COAX, A1-A2	01/06/14	GJH	14-0007	DE
pg2	D	ADD PG3, ADD NOTE 5	02/03/17	MCS	17-0050	SC
pg3	F	REMOVE MODE SELECT	10/27/17	SC	17-0637	WE

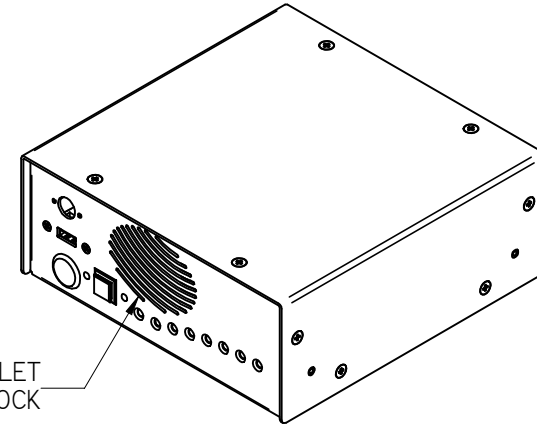

AIR VENT IN-LET
DO NOT BLOCK

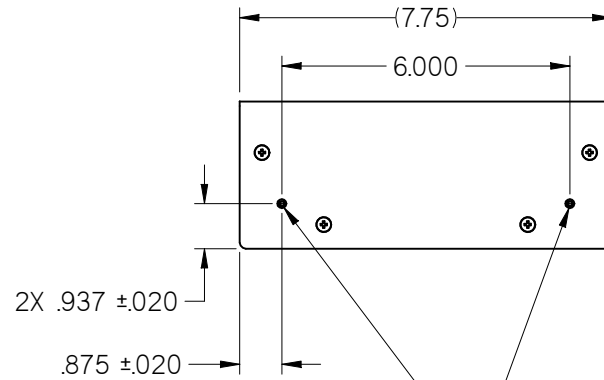
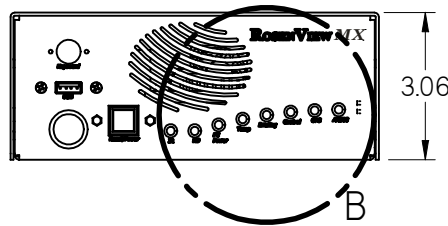

2x 6-32 MOUNTING HOLES
-BOTH SIDES
-DO NOT EXCEED .25" MAXIMUM
INSERTION DEPTH FOR MOUNTING
HARDWARE

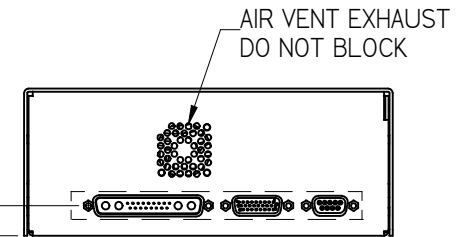

AIR VENT EXHAUST
DO NOT BLOCK

DETAIL A, SEE
SHEET 3

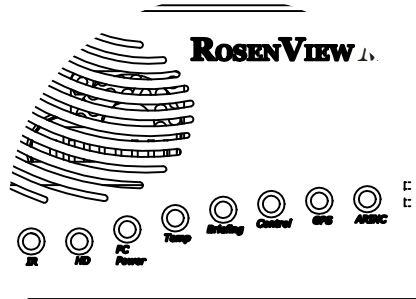

DETAIL B

THE INFORMATION CONTAINED HEREIN IS PROPRIETARY TO ROSEN AVIATION, LLC. IT SHALL NOT BE REPRODUCED OR DISCLOSED IN WHOLE OR IN PART OR USED FOR ANY DESIGN OR MANUFACTURE EXCEPT WHEN SUCH USER POSSESSES DIRECT, WRITTEN AUTHORIZATION FROM ROSEN AVIATION. THIS DRAWING MAY BE COVERED UNDER ONE OR MORE U.S. OR INTERNATIONAL PATENTS, PLEASE CONTACT ROSEN AVIATION FOR SPECIFIC INFORMATION.

ROSEN AVIATION 1020 OWEN LOOP SOUTH EUGENE, OREGON 97402 TEL: (541) 342-3802 FAX: (541) 342-4912	APPROVALS	INITIAL	DATE
	DRAWN BY	GJH	06/25/13
	CHECKER	JC	11/06/13
	ENGINEER	GJH	11/11/13
TITLE	DWG NO		
OUTLINE AND INSTALLATION DRAWING ROSENVIEW MX	0603-003-CD		
FIRST CALLED FOR: (FCF)	SIZE	REV	
-353	A	F	
	SCALE 1:4	SHEET	1 OF 3

UNLESS OTHERWISE SPECIFIED DIMENSIONS ARE IN INCHES
.XX = ± .030
.XXX = ± .010
\sum = ± 1.0'
RADII ± .020
INTERPRET DIM AND TOL PER ASME Y14.5M - 1994

1

2

VIEWS THIS SHEET DEPICT MOD 02
SEE SHEET 1 FOR OUTLINE AND
MOUNTING DIMENSIONS

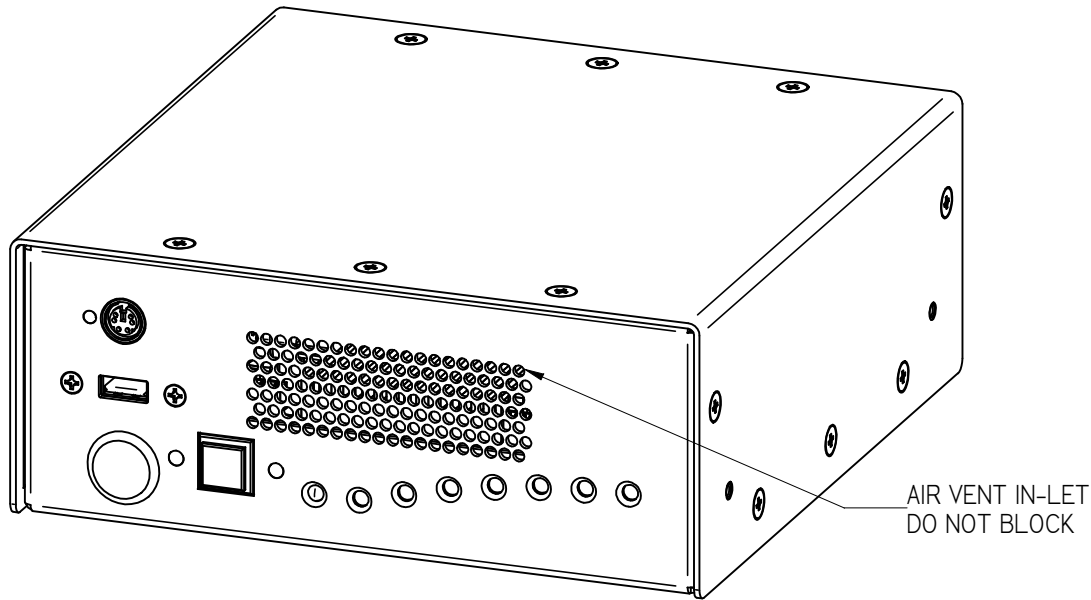
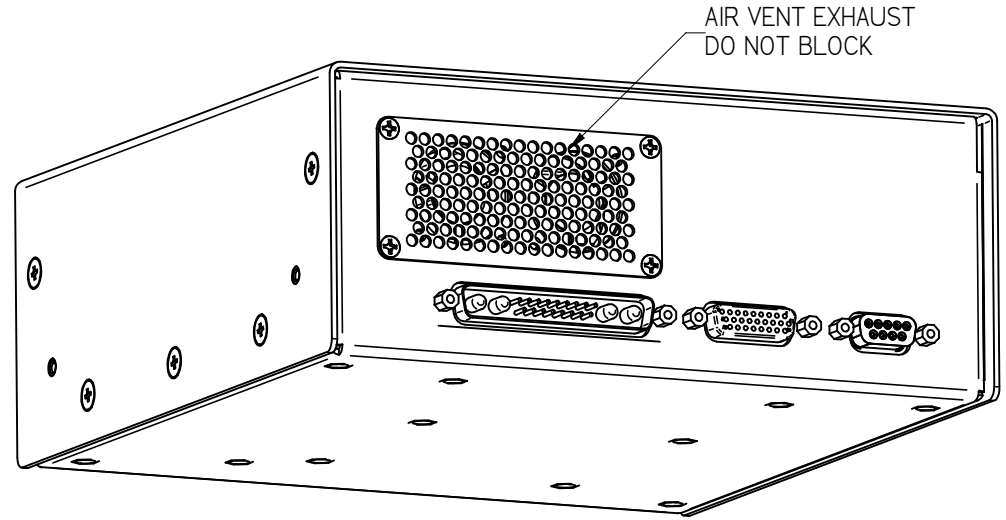

THE INFORMATION CONTAINED HEREIN IS PROPRIETARY TO ROSEN AVIATION, LLC. IT SHALL NOT BE REPRODUCED OR DISCLOSED IN WHOLE OR IN PART OR USED FOR ANY DESIGN OR MANUFACTURE EXCEPT WHEN SUCH USER POSSESSES DIRECT, WRITTEN AUTHORIZATION FROM ROSEN AVIATION, LLC. THIS DRAWING MAY BE COVERED UNDER ONE OR MORE U.S. OR INTERNATIONAL PATENTS, PLEASE CONTACT ROSEN AVIATION FOR SPECIFIC INFORMATION.

ROSEN
AVIATION

1020 OWEN LOOP SOUTH
EUGENE, OREGON 97402
TEL: (541) 342-3802 FAX: (541) 342-4912

SIZE A	DWG NO 0603-003-CD	REV F
SCALE NONE	SHEET 2 OF 3	

1

2

©2014 ROSEN AVIATION, LLC

J1 - MAIN INTERFACE CONNECTOR - 21WA4

Connector Type: Combo-D 21WA4 (Male)	
Rosen Connector Kit: 0300-034 (Included)	
Pin #	Signal
1	28V return
2	28V
3	TTL in -Briefing 1 sw itch input* (Ground Active)
4	TTL in -Briefing 2 sw itch input* (Ground Active)
5	TTL in -Briefing 3 sw itch input* (Ground Active)
6	TTL in -Briefing 4 sw itch input* (Ground Active)
7	TTL in -Briefing play sw itch input* (Ground Active)
8	In-Briefing cancel sw itch input (Ground Active)
9	RESERVED
10	28V Return (not necessary if Pin 1 connected)
11	28V (not necessary if Pin 2 conected)
12	Audio mute (PA override) input (Ground Active)***
13	Briefing Active LED ouput*
14	Briefing Active ouput**
15	Briefing Active Output(ground active)**
16	Discrete out 4 (unassigned)**
17	GND
Coax Pin A1	N/C
Coax Pin A2	N/C
Coax Pin A3	Composite Video out 1
Coax Pin A4	Composite Video out 2

Notes:
 *Pins 3-8 and 13 are usually connected to the optional Rosen 0300-410 Briefing Control Panel. All inputs are activated by momentary sw itches to ground. Pin 13 is used to connect to a LED, 2V at 10-15 mA
 ** Discrete ouput pins 14 and 16 are 5V active logic outputs. DO NOT connect these pins to any device w ith an open circuit voltage greater than 5V DC. Pin 14 is 5V at 15mA maximum w hile briefing is active, pin 15 is 28V tolerant output low w hen briefing is active.
 Contact Rosen for custom configurations of unassigned pins.
 *** Pauses briefing w hen active

J2 - Data Interface Connector - 26 Pin D-Sub

Connector Type: 26 pin High Density D-Sub(Female)	
Rosen Connector Kit: 0300-032 (Included)	
Pin #	Signal
1	Left Audio Signal Out
2	Audio GND
3	Right Audio Signal Out
4	GND
5	ARINC 429 Data - Data reciever 1 positive input
6	ARINC 429 Data - Data reciever 1 negative input
7	ARINC 429 Data - Data reciever 2 positive input
8	ARINC 429 Data - Data reciever 2 negative input
9	Discrete Out (unassigned)
10	RS232 Input (GPS)
11	RS232 GND(Do not attach to aircraft ground)
12	NC
13	RS-485 A input
14	RS-485 B input
15	RS-485 A output
16	RS-485 B output
17	GND
18	RS232 Input (control)
19	RS232 output (control) (unassigned)
20	RS232 gnd (control)(Do not attach to aircraft ground)
21	Discrete Out (unassigned)
22	IR + 5V output
23	Demodulated IR Signal input*
24	IR Ground*
25	Discrete Out (unassigned)
26	GND

Note:
 * Do NOT connect any device to pin 23 that has a signal voltage greater than 5V. Do NOT connect an unmodulated IR reciever such as a pin diode from an IR repeater.

J3 - ANALOG RGB - 15 Pin VGA

Connector Type: 15 pin High Density VGA (Female)	
Rosen Connector Kit: 0300-026 (Included)	
Pin #	Signal
1	Red signal
2	Green signal
3	Blue signal
4	NC
5	GND
6	GND (Red return)
7	GND (Green return)
8	GND (Blue return)
9	NC
10	GND (Sync return)
11	NC
12	NC
13	H Sync
14	V Sync
15	NC

Performance Specifications (Reference)

Power Requirements	
Nominal Voltages	28VDC
Nominal Current	1.1A ±10%

Environmental Specifications

Operating Temperature	0 °C to 50 °C
Altitude	A1 (50,000ft)
Humidity	A
Vibration	CAT S, Curve B2
Power Input	A, B
Radio Frequency	TT
Emission of RF Energy	M

OPTIONAL CONTROLLERS	
(PASSENGER) 7 BUTTON CONTROLLER, BRUSHED ALUMINUM	0300-407
(COCKPIT) BRIEFING CONTROLLER, BLACK	0300-410
(COCKPIT) BRIEFING CONTROLLER, GRAY	0300-411
ROSENVIEW BRIEFING CONTROLLER, GRAY	0300-412

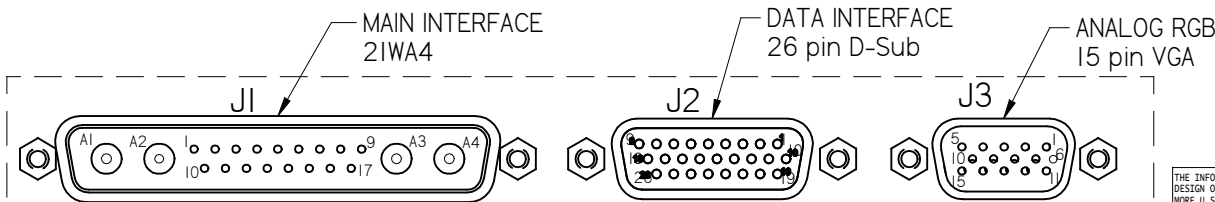

DETAIL A, SEE SHEET I

THE INFORMATION CONTAINED HEREIN IS PROPRIETARY TO ROSEN AVIATION, LLC. IT SHALL NOT BE REPRODUCED OR DISCLOSED IN WHOLE OR IN PART OR USED FOR ANY DESIGN OR MANUFACTURE EXCEPT WHEN SUCH USER POSSESSES DIRECT, WRITTEN AUTHORIZATION FROM ROSEN AVIATION, LLC. THIS DRAWING MAY BE COVERED UNDER ONE OR MORE U.S. OR INTERNATIONAL PATENTS. PLEASE CONTACT ROSEN AVIATION FOR SPECIFIC INFORMATION.

	1020 OWEN LOOP SOUTH EUGENE, OREGON 97402 TEL: (541) 342-3802 FAX: (541) 342-4912	SIZE DWG NO A 0603-003-CD	REV F
	SCALE NONE SHEET 3 OF 3		