

NOTES: (UNLESS OTHERWISE SPECIFIED)

1. COSMETIC BACK ASSEMBLY WEIGHT: 4.5 LBS MAX
2. SOME MINOR PARTS, LABELS, HARNESSES AND INSTRUCTIONS OMITTED FOR CLARITY
3.  DENOTES ROSEN FAI DIMENSION

# ELECTRONIC REVISION CONTROLLED

REVISIONS						
ZONE	REV	DESCRIPTION	DATE	BY	EC NO	APRV
	1.0	INITIAL DRAWING RELEASE	01/20/14	GJH	NEC14-019	JC
	A	RELEASE FOR PRODUCTION	06/23/14	GJH	14-0239	
	B	NOTE 1 4.5 WAS 4.3	10/13/16	BEF	16-0450	MCS

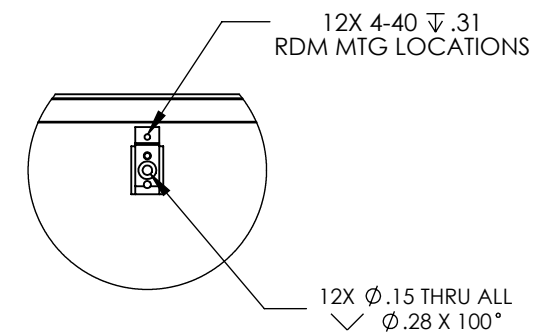
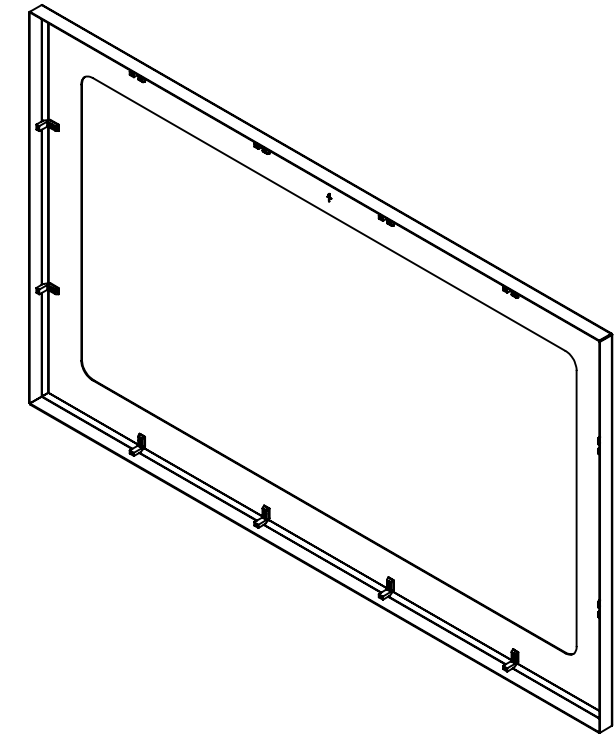
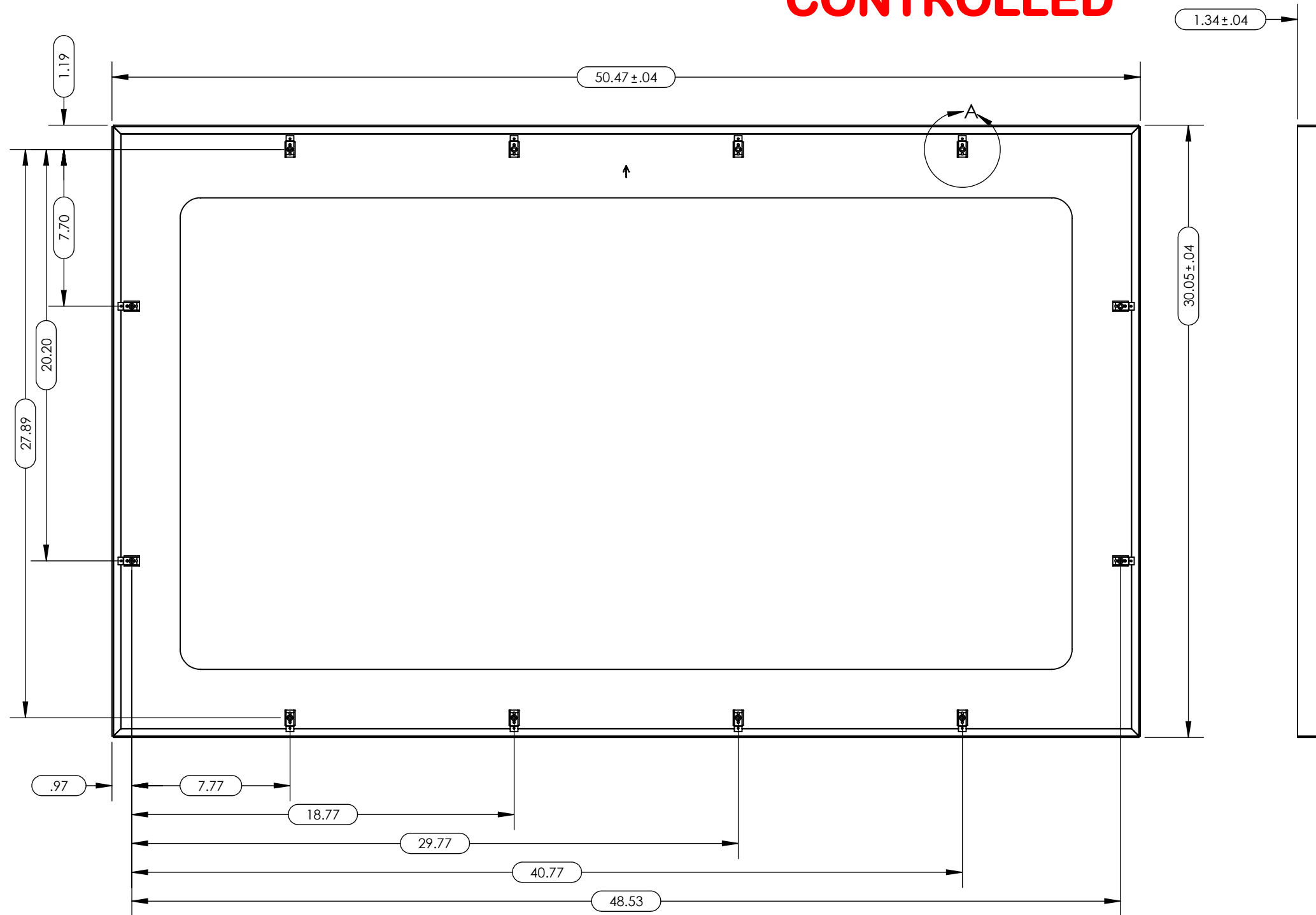

THE INFORMATION CONTAINED HEREIN IS PROPRIETARY TO ROSEN AVIATION, LLC. IT SHALL NOT BE REPRODUCED OR DISCLOSED IN WHOLE OR IN PART OR USED FOR ANY DESIGN OR MANUFACTURE EXCEPT WHEN SUCH USER POSSESSES DIRECT, WRITTEN AUTHORIZATION FROM ROSEN AVIATION, LLC. THIS DRAWING MAY BE COVERED UNDER ONE OR MORE U.S. OR INTERNATIONAL PATENTS, PLEASE CONTACT ROSEN AVIATION FOR SPECIFIC INFORMATION.

	1020 OWEN LOOP SOUTH EUGENE, OREGON 97402 TEL: (541) 342-3802 FAX: (541) 342-4912		APPROVALS	INITIAL	DATE
			DRAWN BY	DE	01/15/14
			CHECKER	BEF	04/03/14
			ENGINEER	GJH	06/23/14
<b>TITLE</b> OUTLINE & INSTALLATION DRAWING COSMETIC BACK, 55in			<b>5501-800-CD</b>		
FIRST CALLED FOR: (FCF) 50in Plus - 318			SIZE <b>B</b>	REV <b>B</b>	
			SCALE: 1:6	SHEET 1 OF 1	

UNLESS OTHERWISE SPECIFIED DIMENSIONS ARE IN INCHES

.X = ± .1  
.XX = ± .03  
∠ = ± 3°

INTERPRET DIM AND TOL PER ASME Y14.5M - 1994