

NOTES: (UNLESS OTHERWISE SPECIFIED)

- 1. ASSEMBLY WEIGHT: 2.65 LBS. MAX
- 2. SOME MINOR PARTS, LABELS, HARNESSES AND INSTRUCTIONS OMITTED FOR CLARITY
- 3. DENOTES ROSEN AVIATION INSPECTION DIMENSION

**ELECTRONIC REVISION  
CONTROLLED**

REVISIONS						
ZONE	REV	DESCRIPTION	DATE	BY	EC NO	APRV
	1.0	INITIAL DRAWING RELEASE	04/24/14	GJH	NEC14-089	BEF
	A	RELEASE FOR PRODUCTION	06/23/14	GJH	14-0239	

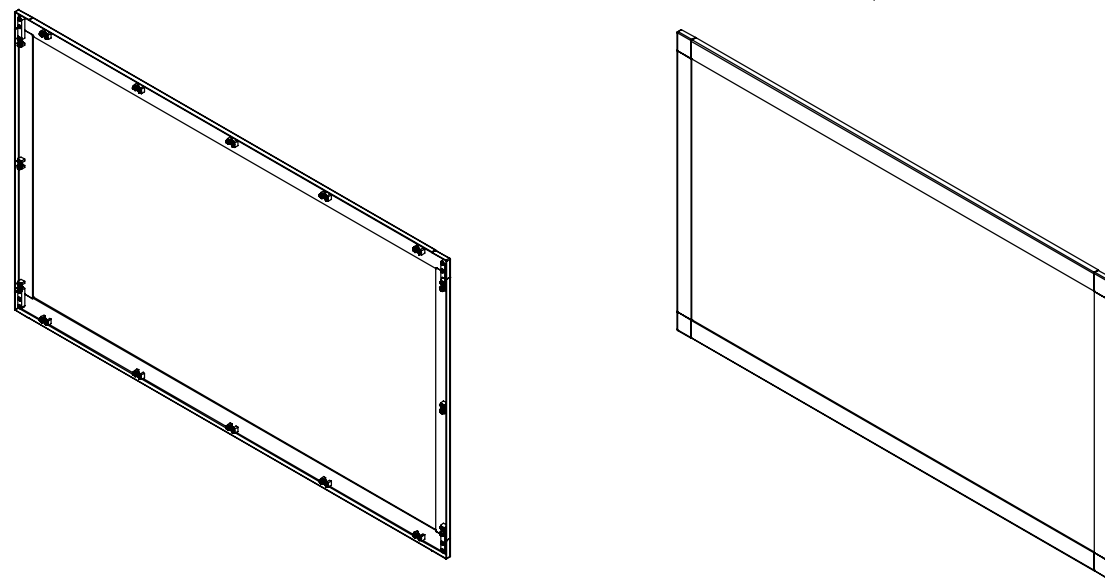
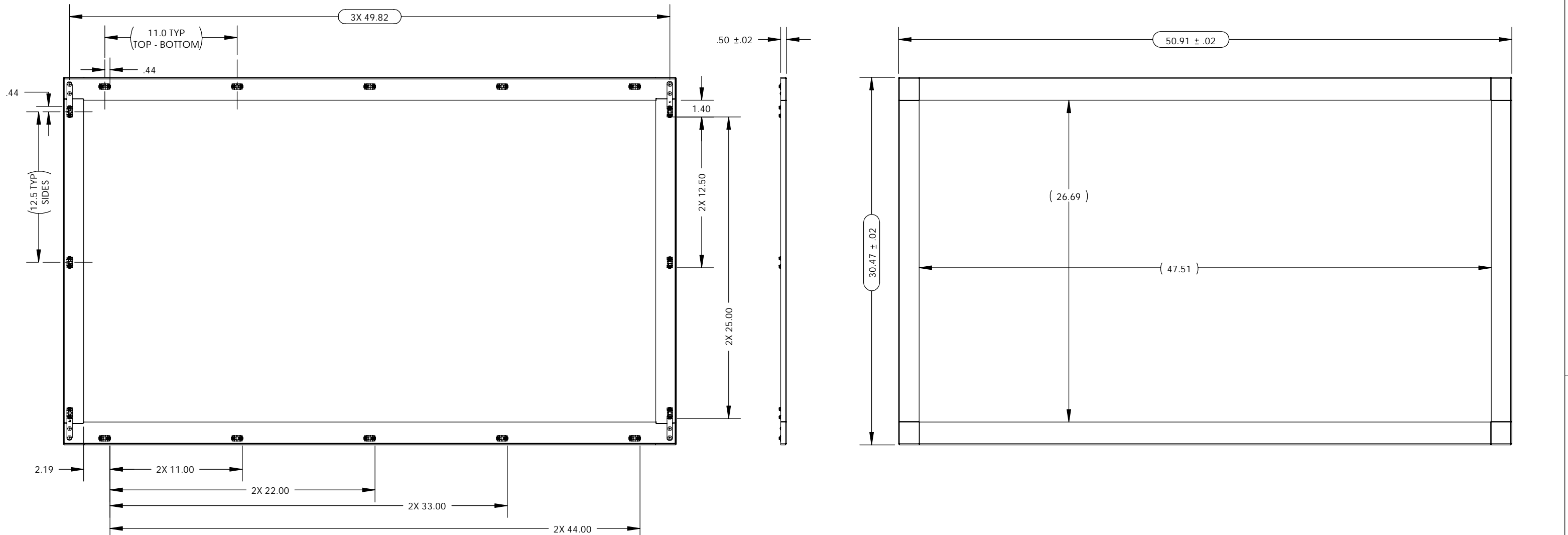

THE INFORMATION CONTAINED HEREIN IS PROPRIETARY TO ROSEN AVIATION, LLC. IT SHALL NOT BE REPRODUCED OR DISCLOSED IN WHOLE OR IN PART OR USED FOR ANY DESIGN OR MANUFACTURE EXCEPT WHEN SUCH USER POSSESSES DIRECT, WRITTEN AUTHORIZATION FROM ROSEN AVIATION, LLC. THIS DRAWING MAY BE COVERED UNDER ONE OR MORE U.S. OR INTERNATIONAL PATENTS, PLEASE CONTACT ROSEN AVIATION FOR SPECIFIC INFORMATION.

	1020 OWEN LOOP SOUTH EUGENE, OREGON 97402 TEL: (541) 342-3802 FAX: (541) 342-4912		APPROVALS	INITIAL	DATE
			DRAWN BY	GJH	04/24/14
			CHECKER	SC	05/14/14
			ENGINEER	GJH	06/23/14
<b>TITLE</b> OUTLINE & INSTALLATION DRAWING BEZEL, RAW, 55" RDM			<b>5501-900-CD</b>		
FIRST CALLED FOR: (FCF) 50in Plus - 318			SIZE		REV
			B		A,
			SCALE: 1:8	SHEET 1 OF 1	

UNLESS OTHERWISE SPECIFIED DIMENSIONS ARE IN INCHES

.X = ± .1  
.XX = ± .03

∠ = ± 5.0°  
RADII ± .020

INTERPRET DIM AND TOL PER ASME Y14.5M - 1994